

de Montageanleitung
en Mounting instructions
fr Instructions de montage
sv Monteringsinstruktion
nl Montage-aanwijzing
it Istruzioni di montaggio
fi Asennusohje
es Instrucciones de montaje
da Monteringsvejledning
pl Instrukcja montażu
cz Montážní návod
hu Szerelési útmutató
el Οδηγίες εγκατάστασης
ru Инструкция по установке
zh 安裝指導

Stellantriebe
Actuators
Servomoteur
Ställdon
Servomotoren
Servocomandi
Toimimoottorit
Actuadores
Motorer
Silowniki
Pohony
Motorok
Κινητήρες
Приводы
执行器

Type	Part no.
SQD35.00FRS	53-1054
SQD85.03FRS	53-1053
SQD65FRS	53-1052

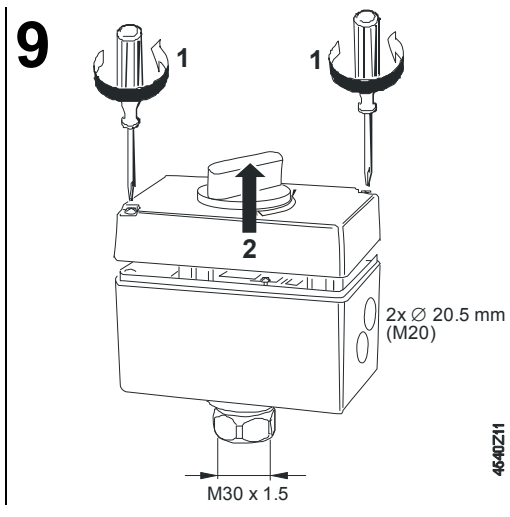
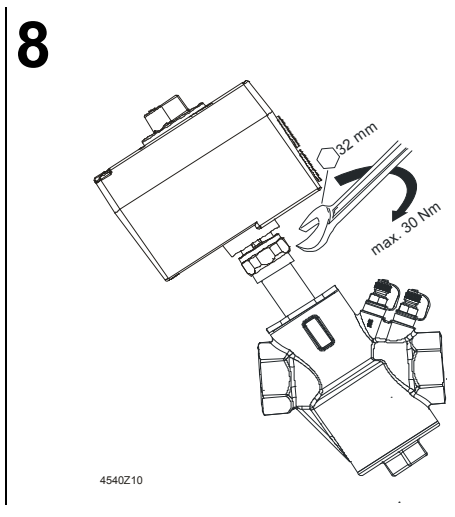
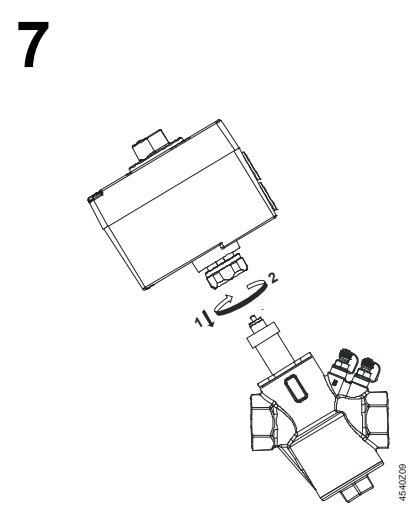
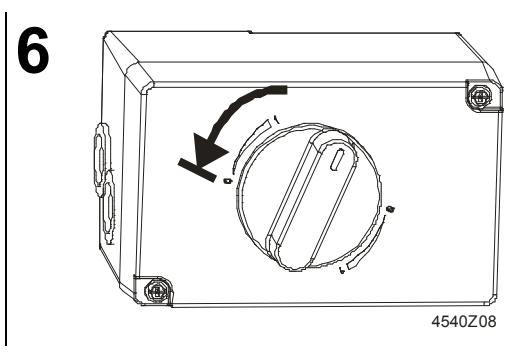
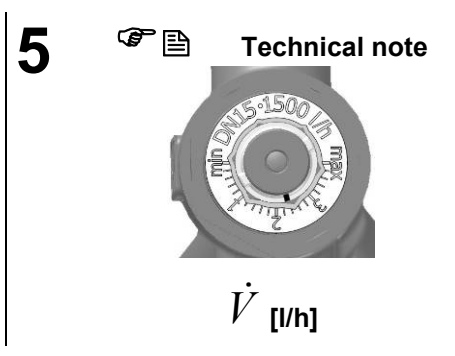
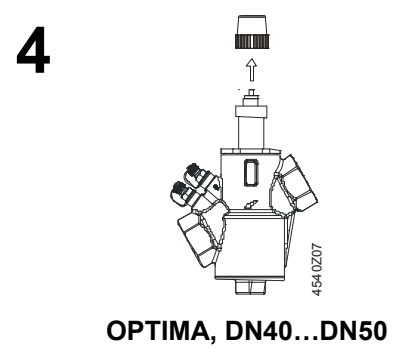
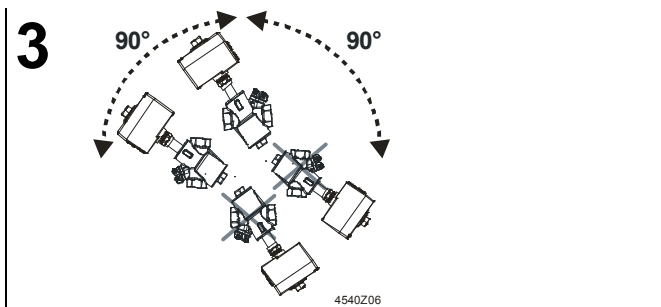
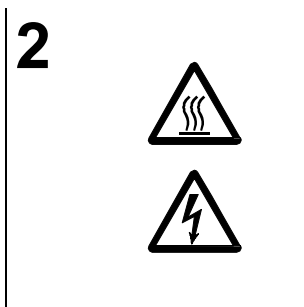
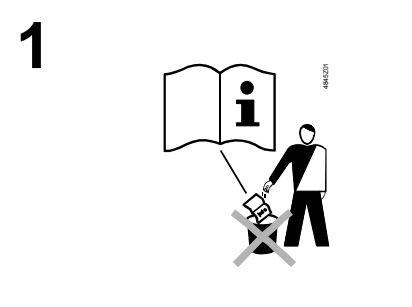

SQD35.00FRS / SQD85.03FRS

7a

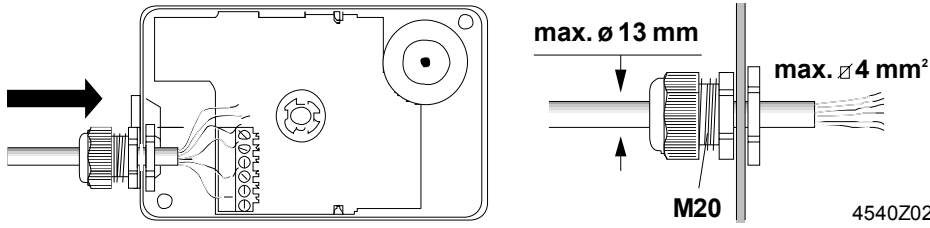

4540Z02

SQD35.00FRS

8a

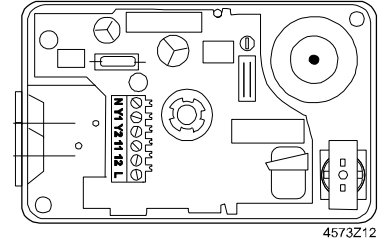
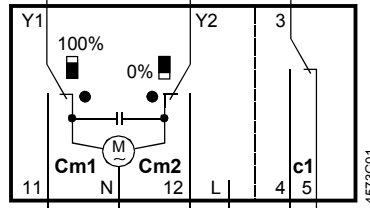
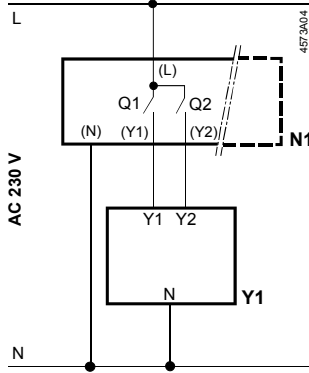

4573Z12

SQD85.03FRS

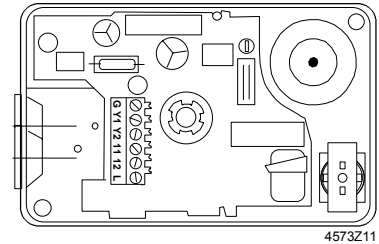
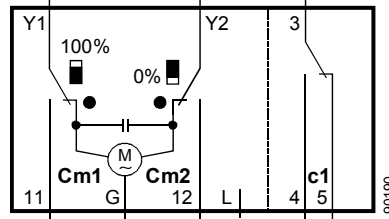
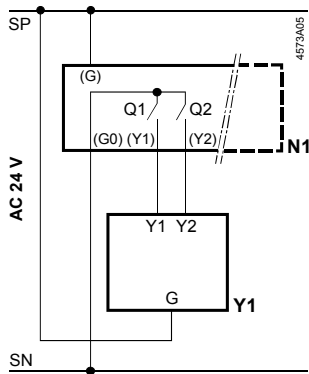

4573Z11

c1	ASC9.6
Cm1	 100% → Y1 → 11 4540Z03
Cm2	 0% → Y2 → 12 4540Z4

Y1	↓	→	100 %
Y2	↑	→	0 %
G		~	AC 24 V
G0	-	~	AC 24 V
L		~	AC 230 V
N		~	AC 230 V

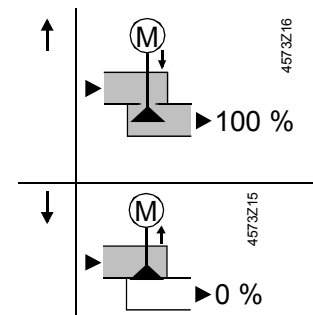

4573Z16

4573Z15

7b

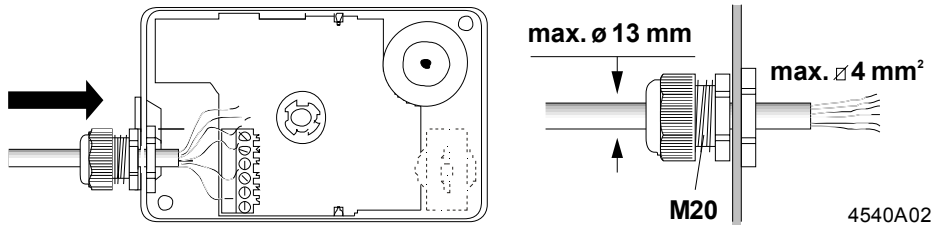

8b

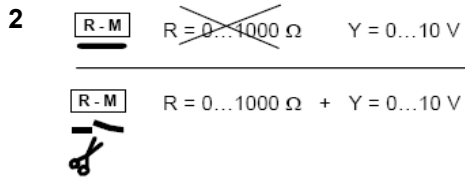
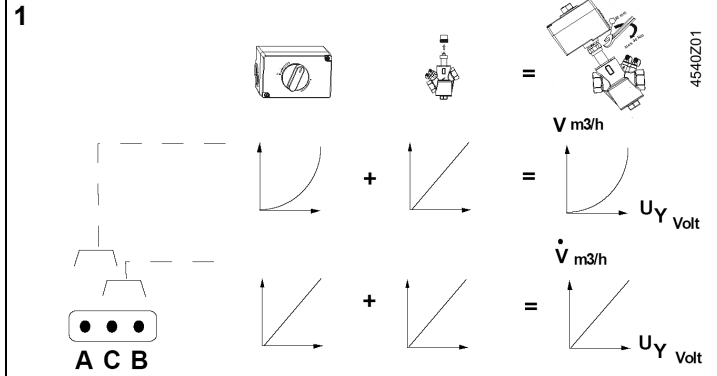
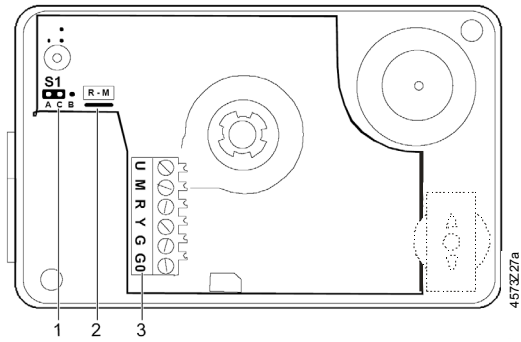

3

U	+	→	DC 0...10 V, ≤ 0.5 mA
M	-		
R	+	←	0...1000 Ω (R - M)
Y	+	←	DC 0...10 V, ≤ 0.1 mA
G		~	AC 24 V
G0	-	~	AC 24 V

4573Z06

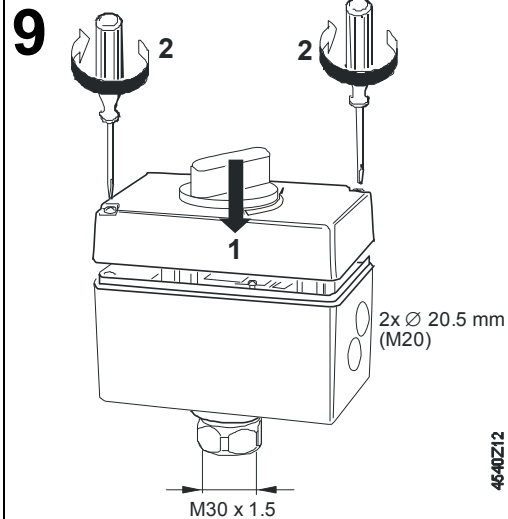
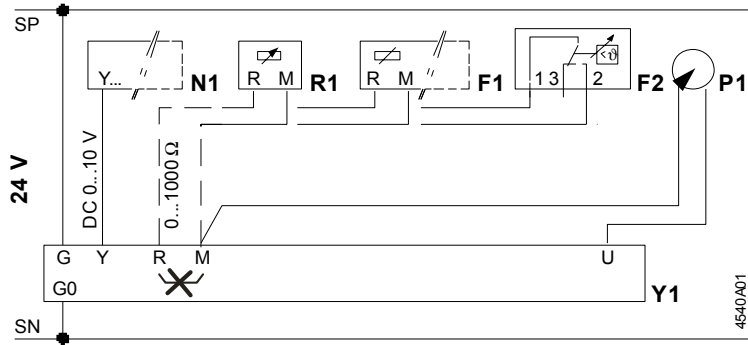

	N1	R1	F1	F2	P1	Y1	SP, G	SN, G0, M	Y	U
de	Regler	Stellungsgeber 0...1000 Ω	Frostschutzwächter 0...1000 Ω	Frostschutz- thermostat	Stellungs- anzeige	Stellantriebe	System- potential	Systemnull	Stellsignal	Stellungs- rückmeldung
en	Controller	Signal indicator 0...1000 Ω	Frost protection monitor 0...1000 Ω	Frost protection thermostat	Position indicator	Actuators	System poten- tial	System neutral	Control signal	Position indica- tion
fr	Régulateur	Potentiomètre de position 0...1000 Ω	Thermostat antigel 0...1000 Ω	Thermostat antigel	Indicateur de position	Servomoteurs	Potentiel du sys- tème	Zéro du sys- tème	Signal de commande	Recopie de position
sv	Regulator	Lägesgivare	Frysvakt 0...1000 Ω	Frostskydds- termostat	Läges- indikering	Ställdon	System- potential	Systemnoll	Styrsignal	Lägesindikator
nl	Regelaar	Potentiometer 0...1000 Ω	Vorstbeveiliging 0...1000 Ω	Vorstthermostaat	Stand- aanwijzing	Servomotor	Systeem- potentiaal	Systeemnul	Besturings- signaal	Stand- terugmelding
it	Regolatore	Potenzimetro di posizionamento 0...1000 Ω	Protezione antigelo 0...1000 Ω	Termostato anti- gelo	Indicazione posiziona- mento	Attuatore	Fase del siste- ma	Neutro del sistema	Segnale di comando	Indicazione di posizione
fi	Säädin	Viestin indikointi 0...1000 Ω	Jäätymisvahti 0...1000 Ω	Jäätymissuoja- termostaatti	Asennon indikointi	Toimimootorit	Järjestel- mäpotentiaali	Järjestel- mänolla	ohjausviesti	Asennon in- dikointi
es	Controlador	Indicador de señal 0...1000 Ω	Monitor protección antihielo 0...1000 Ω	Termostato pro- tección antihielo	Indicador de posición	Actuador	Fase CA para equipos	Neutro CA para equipos	Señal de con- trol	Indicación de posición
da	Regulator	Stillingsgiver 0...1000 Ω	Frostbeskyttelses- vagt 0...1000 Ω	Frostbeskyttelses- termostat	Positions- indikering	Motorer	System-fase	System-nul	Styre-signal	Positions- indikation
pl	Regulator	Wskaźnik położenia 0...1000 Ω	Monitor przeciwza- marzaniowy 0...1000 Ω	Termostat prze- ciwzamarzaniowy	Wskaźnik położenia	Silowniki	Potencjał systemowy	Zero syste- mowe	Sygnat steru- jący	Wskazanie położenia
cz	Regulátor	Vyslač polohy s výstupem 0...1000 Ω	Monitoring mrazové ochrany s výstupem 0...1000 Ω	Protimrazový termostat	Indikace polohy	Pohony	Systémový potenciál	Systémová nula	Řídící signal	Indikace polohy
hu	Szabályozó	Felülvezérlés 0...1000 Ω	Fagyvédelem 0...1000 Ω	Fagyvédelmi termosztát	Pozíció- visszajelzés	Szelepmoz- gató	Rendszer fázis	Rendszer nulla	Vezérlőjel	Pozíció vissza- jelzés
el	Ελεγκτής	Ένδειξη θέσης 0...1000 Ω	Αισθ. αντιπαγετικής προστασίας 0...1000 Ω	Θερμοστάτης αντιπαγετικής προστασίας	Ένδειξη θέσης	Κινητήρας	Φάση	Ουδέτερος	Σήμα ελέγχου	Επιβεβαίωση θέσης
ru	Контрол- лер	Индикатор сигнала 0...1000Ω	Устройство защиты от замораживания 0...1000 Ω	Термостат защи- ты от заморажи- вания	Индикатор положения	Приводы	Системный потенциал	Системная нейтраль	Управляющий сигнал	Индикатор положения
zh	控制器	位置反馈信号0...10 00 Ω	防霜冻控制 0...1000 Ω	防霜冻温控器	位置指示	执行器	系统供电	系统零线	控制信号	阀位显示