

OPTIMA Compact · DN10-50

Pressure Independent Control Valve



OPTIMA Compact

With OPTIMA Compact you get a dynamic flow, pressure and temperature control valve for heating and cooling systems

OPTIMA Compact combines the functions of an externally adjustable automatic balancing valve with an integrated differential pressure controller and a full authority modulating control valve in one single, compact valve housing.

The OPTIMA Compact provides modulating control with full authority regardless of variations in the differential pressure of the system making it possible to achieve 100% control of the water flow in the building.

In addition, the correct application of the OPTIMA Compact can significantly reduce pump energy consumption and improve the efficiency of other hydronic system components. It also provides optimal comfort for end users due to high precision temperature control.

The valve operates by adjusting automatically to the pre-set flow under fluctuating pressure conditions whilst also providing full modulating control. To achieve the design flow rate, the valve is set using the simple pre-setting scale on top of the valve to the required set point, which can be determined using the official Frese flow graphs or the Frese APP.

OPTIMA Compact is also available in a Veriflow-series. This has a unique P/T plug design which allows for both flow verification and verification of minimum differential pressure across the valve. This is the first pressure independent control valve (PICV) on the market to integrate both functionalities in the original valve housing without add-ons and additional space requirements.

Save Time, Energy and Costs with our Patented Valve Technology

Frese's patented pressure independent technology is an innovative, energy-saving alternative to traditional hydronic balancing and control methods. It provides efficient and accurate flow and differential pressure control.

The pressure independent valves ensure that the design flow conditions are achieved at all times, irrespective of pressure fluctuations in the system.

It also eliminates overflows – resulting in significant pump energy savings.

Dynamic valves hold several other advantages over traditional, static balancing valves. They contribute to simplified system designs by eliminating the need for additional balancing valves in the distribution pipework. They are also highly flexible if your system needs to be modified or expanded at a later date.

Because pressure independent control valves automatically adapt to any changes in the rest of the system, they are much easier to commission since they require no proportional balancing, and now with our Veriflow-series you can also measure and verify the flow of the PICV.

Fan Coil Application Example

In this application example the OPTIMA Compact PICV ensures the balancing of the flow and eliminates the use of both static balancing valves and differential pressure control valves.

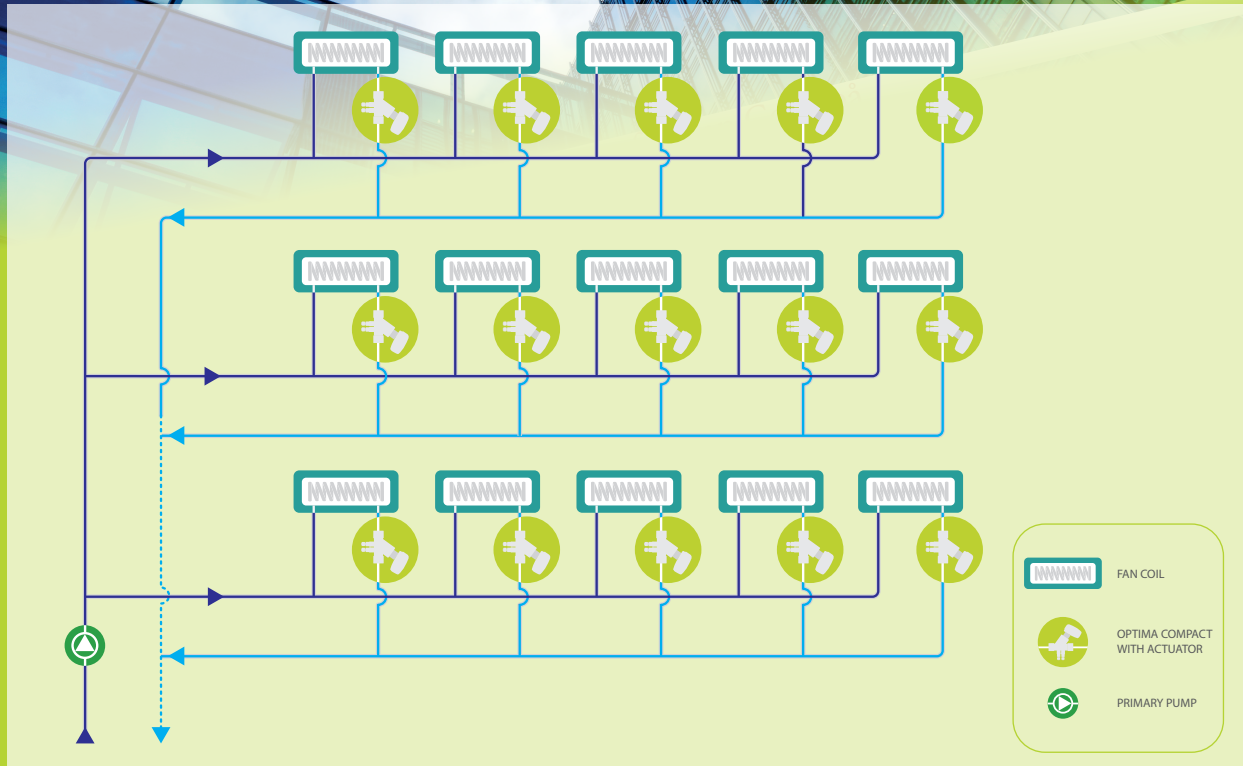

If you choose the LOGICA Digital, Energy-series actuators for these valves, you will get direct communication with BMS via Modbus or BACnet, all the benefits of remote commissioning and no need for a separate controller.

OPTIMA Compact and LOGICA Digital

For over 30 years, Frese has specialised in the design and manufacture of dynamic, pressure independent flow solutions for heating and cooling applications in a wide variety of market sectors including commercial office developments, hotels, educational establishments, sports complexes and residential buildings.

Pressure independent balancing and control

The OPTIMA Compact pressure independent balancing and control valve is the perfect solution for accurate and efficient control of primary and secondary terminal units in variable volume heating and cooling systems.

Typical applications include fan coil units, chilled beams, plate heat exchangers and air handling units.

LOGICA Digital, Energy-series

Paired with an OPTIMA Compact valve, the LOGICA Digital actuator offers intelligent hydronic control and insight.

Easy installation and connection with BMS

The simple and compact system design is easy to install, communicates directly with the BMS and allows a range of operating modes to suit different applications.

Control and reduce energy consumption

The actuator's built-in energy management algorithms and smart features reduce system integration hours and help minimise energy consumption through optimised control and monitoring.

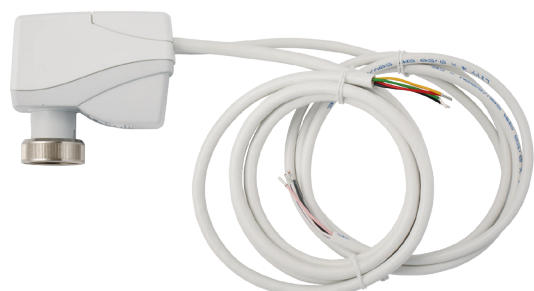

Technical Data



OPTIMA Compact Standard-series DN10 - DN32

Size Range:	DN10 – DN32
Max. Differential Pressure:	800 kPa
Valve Housing:	DZR Brass
Pressure Class:	PN25
Temperature Range:	0°C to 120°C
Flow Range:	30 l/h to 4,001 l/h
Leakage Rate:	EN1349 Class IV

Technical Data



OPTIMA Compact Veriflow-series DN10 - DN32

Size Range:	DN10 – DN32
Max. Differential Pressure:	800 kPa
Valve Housing:	DZR Brass
Pressure Class:	PN25
Temperature Range:	0°C to 120°C
Flow Range:	30 l/h to 4,001 l/h
Leakage Rate:	EN1349 Class IV

Technical Data



OPTIMA Compact Standard-series and Veriflow-series DN40 - DN50

Size Range:	DN40 – DN50
Max. Differential Pressure:	800 kPa
Valve Housing:	Ductile Iron
Pressure Class:	PN25
Temperature Range:	0°C to 120°C
Flow Range:	1,370 l/h to 11,500 l/h
Leakage Rate:	EN1349 Class IV

OPTIMA Compact Actuator Programme DN10-DN50

Frese offers a wide selection of different actuator types ranging from basic on/off control to the latest intelligent LOGICA Digital, Energy-series. This gives us the flexibility to help you find the solution that perfectly suits your specific project.

The actuator programme includes:

- LOGICA Digital, Energy-series (BACnet or Modbus communication)
- Motoric actuator; modulating, failsafe and feedback
- Thermic actuator; modulating or on/off
- Thermostat with remote sensor for water and air



Easy Valve Selection

Frese makes valve selection easy. Simply determine the flow rate of the coil, or load of the system, select the pipe size, and make the selection. Our charts make calculating minimum differential pressure a breeze, and we offer precise verification of both this and the flow. Regardless of fluctuations in the differential pressure the design of the OPTIMA Compact will ensure the most accurate flow control at the selected set point.

DN10 - DN50

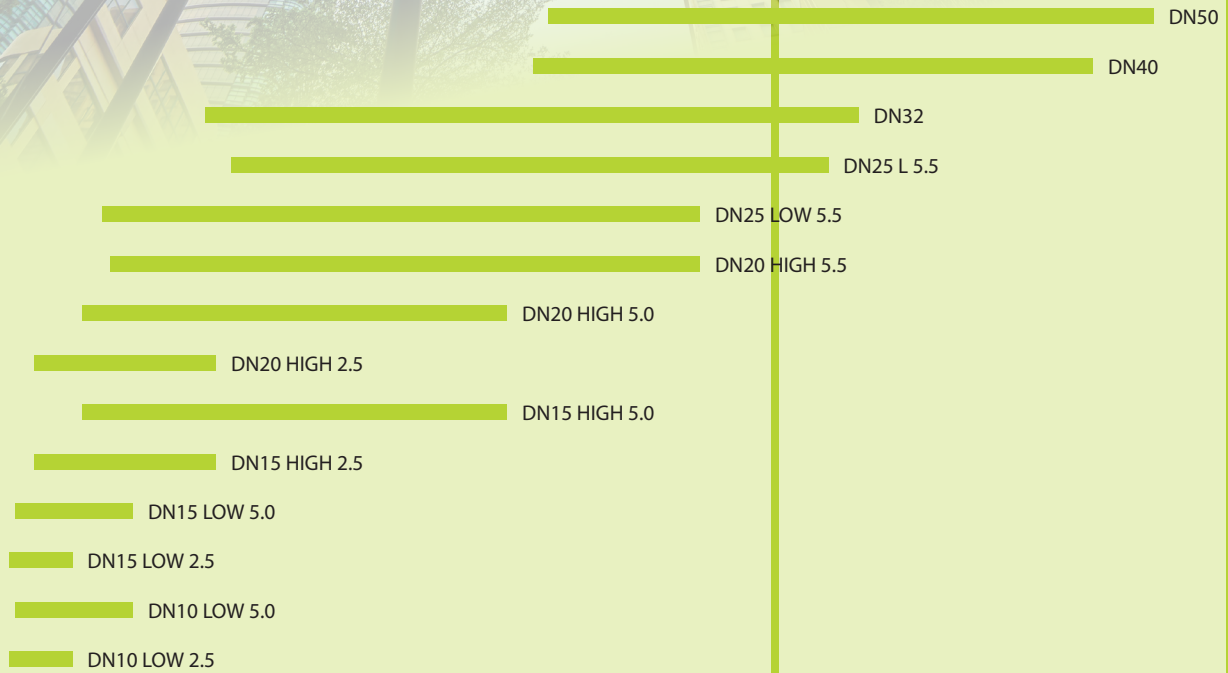

Flow l/h	200	400	600	800	1000	1200	1400	1600	1800	2000	4000	6000	8000	10000	12000
Flow l/s	0.056	0.111	0.167	0.222	0.278	0.333	0.388	0.444	0.500	0.555	1.111	1.666	2.222	2.777	3.333
Flow gpm	0.88	1.76	2.64	3.52	4.40	5.28	6.14	7.04	7.93	8.79	17.60	26.40	35.21	44.01	52.82

The OPTIMA Compact has a very compact design that provides best in class performance.

The main components of the valve are:

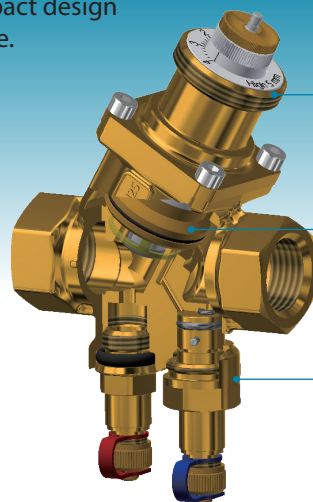

- Presetting scale

- Combined pressure control, flow balancing and modulating control assembly

- Veriflow-series:

- Unique P/T plug allows for both flow verification and verification of minimum DP across the valve

Compact Housing for Easy Installation

See how it works

Visit www.frese.eu/optimacompact and try the interactive animation



www.frese.eu/buildings



info@frese.dk



+45 58 56 00 00